

618

VIPR - Oxygen

TECHNICAL SPECIFICATIONS:

- 2 stage regulating system (300-50 bar / 0-6 bar)
- Pressure indicator (0-360 bar) *Built into the valve body*
- Pressure gauge (0-10 bar) *Built into the valve body*
- 2 stage regulating system, safety valve, RPV in one unit for easy maintainance
- Filter incorporated to protect the regulating unit
- Max flow rate 250 l/min *Min. 20 bar*

For further technical specifications on this valve please see reverse.



Optional Protective guard



90 years of proven experience

Discover more of our products at: www.bmv.dk

TECHNICAL SPECIFICATIONS: 618 VIPR - Oxygen

About this valve

The Müller type 618 industrial VIPR sets new standards with its new innovative design. It is equipped with a two stage regulating unit including safety valve and RPV function. The regulating unit has a patented balanced system allowing you to change the flow settings by applying a constant torque. Pressure gauge and flow meter are incorporated into the main valve body for better protection. For easy maintenance of the regulating unit, the main valve can be shut off and the complete unit can be replaced without further disassembly.

The valve is manufactured in Denmark on state of the art manufacturing equipment, and the quality is monitored throughout the entire process. The valve is assembled on a automated assembly line using Helium as media for accurate leak testing. The valve is subjected to a 100% functional test on the assembly line with complete records of all test results, ensuring full data traceability. When the valve has passed all tests on the assembly line, it is allocated a unique serial number relating to the recorded test data, giving you a world class industrial VIPR!

BAM Approved: according to ISO 22435

Working pressure: 300 bar & 200 bar

Inlet connection: 25E, 25ES, or other on request. Anti dust tube on request

Outlet connection: Quick connect EN 561, screw connection ISO 3253, or other on request

Filling connection: DS2404, DIN, NEN, AFNOR, UNI, NBN, CGA, BS, AS, ISO 5145 or other on request

Outlet pressure: adjustable 0 - 6 bar

Residual pressure valve: 3 - 7,5 bar retain pressure

Safety valve opening: max. 12 bar

Safety valve closing: min. 6,0 bar

He leak tested: leak rate of $\approx 2 \times 10^{-3}$ mBAR x l/sec (6 cm³/h)

Valve weight: 1,9 kg

Valve dimension, height over cylinder: 110 mm (approx)

Opening/closing to cylinder: Handwheel

Regulation of flow: Handwheel

Burst disc: on request

Not for medical use

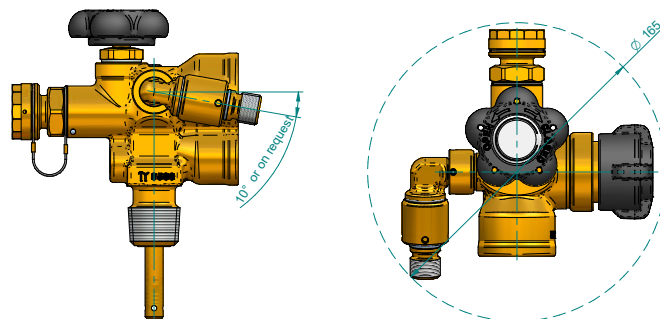
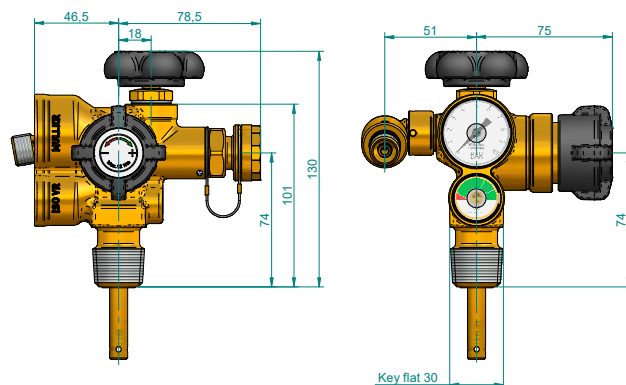

Contact our Sales Department to place your order:

Phone: +45 73 42 12 12 · info@bmv.dk

VIPR for Oxygen type "618" for inlet pressure 300 bar Dynamic expansion curve

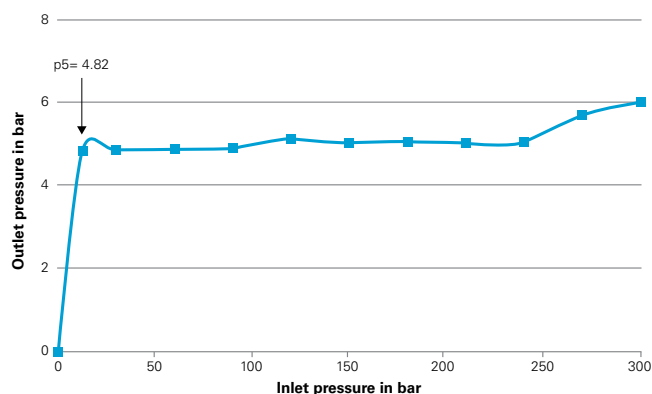

Regulation curve 618-VIPR valve (Oxygen)

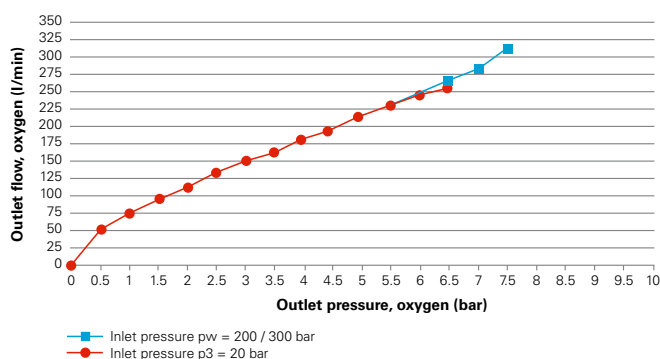

Müller
GAS EQUIPMENT A/S
GAS CONTROL SOLUTIONS

Müller Gas Equipment A/S

Mommarkvej 7-11 · Vollerup · DK-6400 Sønderborg

Telefon: +45 73 42 12 12 · Fax: +45 73 42 12 07 · email: info@bmv.dk · www.bmv.dk

See our online catalogue



Type Approval and IS Authorisation Certificate by:
BAM
BAM-TPED-brP-2011/002